



## Signal conditioner

Contact us

### IPC 704

Unit 402, 4th floor, No. 42, Sharifi St., Jordan St., Tehran, Iran

Tel: 0098-2188779847-Fax 0098-2188779514

www.setc.ir-info@setc.ir

Mob:00989123840728

### FEATURES

- » From the Vibro-Meter® product line
- » For CA xxx piezoelectric accelerometers and CP xxx dynamic pressure sensors
- » Configurable high-pass and low-pass filters
- » Frequency range: 0.5 Hz to 20 kHz
- » Optional integrator to produce a velocity output
- » Optional 2-wire current or 3-wire voltage transmission
- » Certified for use in potentially explosive atmospheres
- » A range of installation options are available



### DESCRIPTION

The IPC 704 signal conditioner converts the charge-based signal from a piezoelectric-based transducer into a current or a voltage signal. This current or voltage signal is transmitted to the processing electronics via a standard 2-wire or 3-wire transmission cable.

The current modulation technique allows transmission over a distance of up to 1 km. A GSI galvanic separation unit is required for this configuration.

The electronic circuitry of the IPC 704 signal conditioner is incorporated into a moulded aluminium enclosure. The signal conditioner has configurable

high-pass and low-pass filters and an optional integrator to give a velocity output. Furthermore, RFI filters protect the input and output against radio-frequency interference and other electromagnetic influences.

A range of installation options are available for the IPC 704 signal conditioner, including:

- » A polyester enclosure providing environmental protection against dust, oil and water jets.
- » A mounting adaptor allowing the IPC 704 signal conditioner to be mounted on a DIN rail.



Information contained in this document may be subject to Export Control Regulations of the European Union, USA or other countries. Each recipient of this document is responsible for ensuring that transfer or use of any information contained in this document complies with all relevant Export Control Regulations. ECN N/A.

**DESCRIPTION** (continued)

Two versions of the IPC 704 signal conditioner are available:

» An IPC 704 for sensors using standard piezoelectric materials, for example, CA xxx, CP 10x and CP 2xx (ordering number 244-704-000-042-...).

» An IPC 704 for sensors using GaPO<sub>4</sub> piezoelectric material, for example, CP 50x (ordering number 244-704-000-511-...).

**BLOCK DIAGRAM**

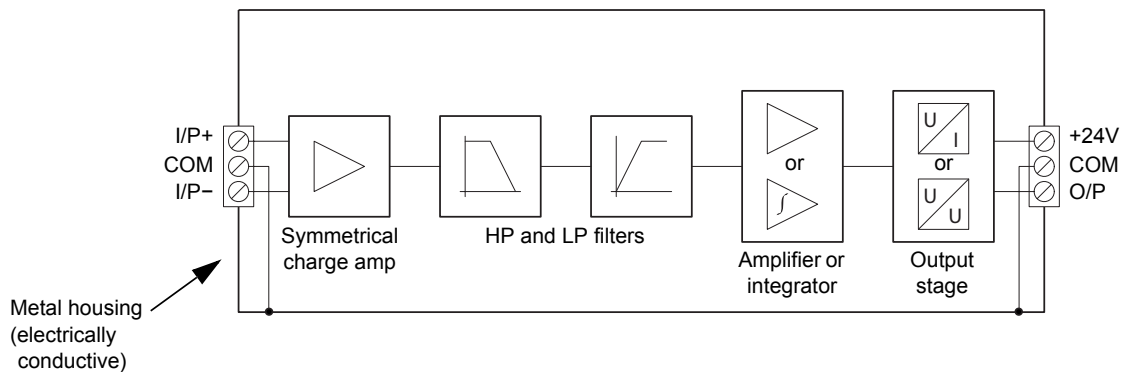

**SPECIFICATIONS**

**Environmental characteristics**

(Specifications according to IEC 60068-2 recommendations)

**General**

Temperature

- Operation : -30 to +85°C
- Storage : -40 to +85°C

Humidity : Max. 95% non-condensing.

Note: For operation in a humid environment, ordering option A3 (potted version) should be considered.

Protection rating (according to IEC 60529) : IP40

Vibration (according to IEC 60068-2-26) : 2 g peak between 10 and 500 Hz

Shock acceleration (according to IEC 60068-2-27) : 15 g peak (half-sine, 11 ms duration)

**Industrial housing (ordering option G1)**

Protection rating (according to IEC 60529) : IP66

Impact resistance : >4 mJ/mm<sup>2</sup> (DIN 53453)

Chemical resistance : Good resistance to seawater, acids, alkaline solutions, gasoline and oils

Flammability : UL94V-0 self-extinguishing

**SPECIFICATIONS** (continued)**Explosive atmospheres**

Available in Ex approved versions for use in hazardous locations

Type of protection Ex i: intrinsic safety (ordering option A2)		
Europe	EC type examination certificate	LCIE 02 ATEX 6085 X II 2G (Zones 1, 2) Ex ib IIC T6 to T4 Gb
North America	cCSAus certificate	cCSAus 1243981 Class I, Div. 1, Groups A, B, C, D Ex ia (T6 to T4)
International	IECEx certificate of conformity	LCI 06.0009X Ex ib IIC T6 to T4 Gb
China	NEPSI certificate of conformity	GYJ12.1450X Ex ib IIC T6 to T4 Gb
Korea	KGS certificate of conformity	12-GA4BO-0396X Ex ib IIC T6 to T4

 **For specific parameters of the mode of protection concerned and special conditions for safe use, please refer to the certificates that are available from Meggitt SA on demand.**

Type of protection Ex nA: non-sparking apparatus (ordering option A3)		
Europe	Voluntary type examination certificate	LCIE 09 ATEX 1027 X II 3G (Zone 2) Ex nA IIC T6 to T5 Gc

 **When using protection mode 'nA' (non-sparking apparatus), the user shall ensure that the signal conditioner is installed in an enclosure that ensures a protection rating of at least IP54 (or equivalent).**

**Industrial housing (ordering option G1)**

Available in Ex approved versions for use in hazardous locations

- *Environment* : II 2 G (Zones 1, 2) Ex e II
- *Surface resistivity for Ex version* : <math>10^9 \Omega</math> (DIN 53482)

**Stuffing glands**

Available in Ex approved versions for use in hazardous locations

- *Environment* : II 2 G/D (Zones 1, 2) Ex e II

 **For specific parameters of the mode of protection concerned and special conditions for safe use, please refer to the certificates that are available from Meggitt SA on demand.**

**Power supply to IPC 704**

- Voltage : 18 to 30 V<sub>DC</sub>
- Current : 25 mA (max.)

Contact us

Unit 402, 4th floor, No. 42, Sharifi St., Jordan St., Tehran, Iran

Tel: 0098-2188779847-Fax 0098-2188779514

[www.setc.ir-info@setc.ir](mailto:www.setc.ir-info@setc.ir)

Mob:00989123840728

**SPECIFICATIONS** (continued)

**Transfer characteristics (ordering option B)**

IPC 704 for sensors using standard piezoelectric materials (244-704-000-042-...)

- *Transfer without integrator* : 0.1 to 10 mV/pC or 0.1 to 10  $\mu$ A/pC
- *Transfer with integrator* : 981 to 98 100 mV/(pC.s) or 981 to 98 100  $\mu$ A/(pC.s)

IPC 704 for sensors using GaPO<sub>4</sub> piezoelectric material (244-704-000-511-...)

- *Transfer* : 0.1 to 50 mV/pC or 0.1 to 50  $\mu$ A/pC
- Linearity error :  $\leq 0.2\%$
- Temperature stability : 100 ppm/ $^{\circ}$ C typical
- Phase : 180 $^{\circ}$  between the input signal and the acceleration output.  
180 $^{\circ}$  between the input signal and the pressure output.  
90 $^{\circ}$  between the acceleration and velocity outputs.  
(See graph below.)

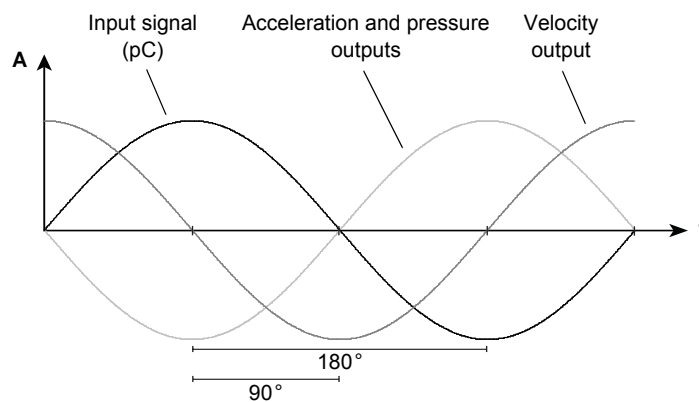

**Input characteristics (ordering option C)**

- Compatible sensors : Any piezoelectric-based transducer, symmetrical or non-symmetrical, case grounded or insulated
- Dynamic range : 100000 pC peak
- Input sensitivity : Accelerometer: 10 to 200 pC/g.  
Dynamic pressure transducer: 10 to 1000 pC/bar.
- Charge amplifier : Symmetrical
- RFI filter : Symmetrical LC network
- Resistance :  $\geq 50$  k $\Omega$  (sensor and cable)
- Capacitance :  $\leq 10$  nF (sensor and cable)

**Output characteristics (ordering option D)**

- RFI filter : Symmetrical LC network
- 2-wire current transmission
- *Dynamic signal* : Max.  $\pm 5$  mA peak
- *Standing current* : 12 mA  $\pm 0.5$  mA
- *Electrical connection* : +24 V = "+", COM = "-"
- *Output sensitivity* : See ordering information
- *Max. dynamic range* : 5 mA peak/output sensitivity

**SPECIFICATIONS** (continued)

3-wire voltage transmission

- *Dynamic signal* : Max.  $\pm 5$  V peak
- *Standing voltage* :  $7.5$  V  $\pm 0.2$  V
- *Output sensitivity* : See ordering information
- *Output impedance* :  $750 \Omega$  (3-wire configuration)
- *Max. dynamic range* : 5 V peak/output sensitivity

**⚠ The 3-wire voltage output without galvanic separation unit should only be used with piezoelectric-based transducers which are insensitive to frame voltage. Dynamic pressure transducers should always be used with a GSI galvanic separation unit.**

**Filter characteristics (ordering options E and F)**

**High-pass filter**

- *Cut-off frequencies (at -3 dB)* : 0.5, 1, 2, 5 or 10 Hz (all  $\pm 20\%$ )
- *Slope* : 24 dB/octave (4th order)

**⚠ When selecting a high-pass filter, be careful to select an appropriate frequency for the charge amplifier. See the charge amplifier frequencies versus transfer unit graphs on the following pages.**

**Low-pass filter**

- *Cut-off frequencies (at -1 dB)* : 200, 500, 1000, 2000, 5000, 10000 or 20000 Hz (all  $\pm 10\%$ )
- *Slope* : 12 dB/octave (2nd order)

**Charge amplifier frequencies versus transfer unit**

**IPC 704 for accelerometers (acceleration output) using standard piezoelectric materials**

Ordering number 244-704-000-042-... with ordering options B01 and B02

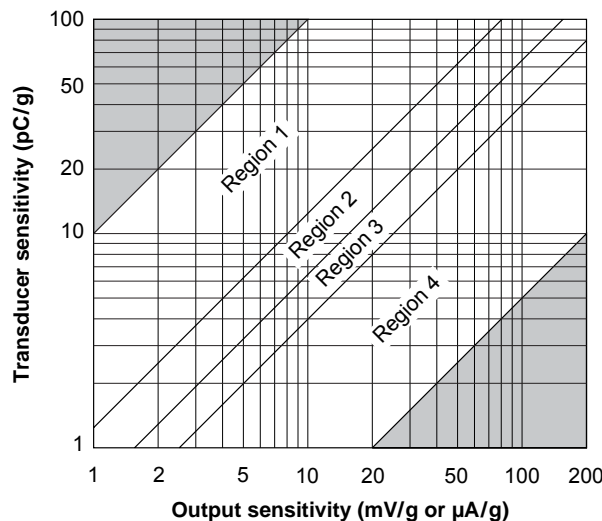

Notes

For operation in different regions of the chart, the cut-off frequency of the IPC 704's charge amplifier dictates the required high-pass filter settings. (See the HP FILTER (E) option in ordering information.)

Region 1: Cut-off frequency is 0.5 Hz  $\rightarrow$  HP filter  $\geq 0.5$  Hz.

Region 2: Cut-off frequency is 1 Hz  $\rightarrow$  HP filter  $\geq 1$  Hz.

Region 3: Cut-off frequency is 2 Hz  $\rightarrow$  HP filter  $\geq 2$  Hz.

Region 4: Cut-off frequency is 3 Hz  $\rightarrow$  HP filter  $\geq 5$  Hz.

SPECIFICATIONS (continued)

IPC 704 for accelerometers (velocity output) using standard piezoelectric materials

Ordering number 244-704-000-042-... with ordering options B03, B04, B05 and B06

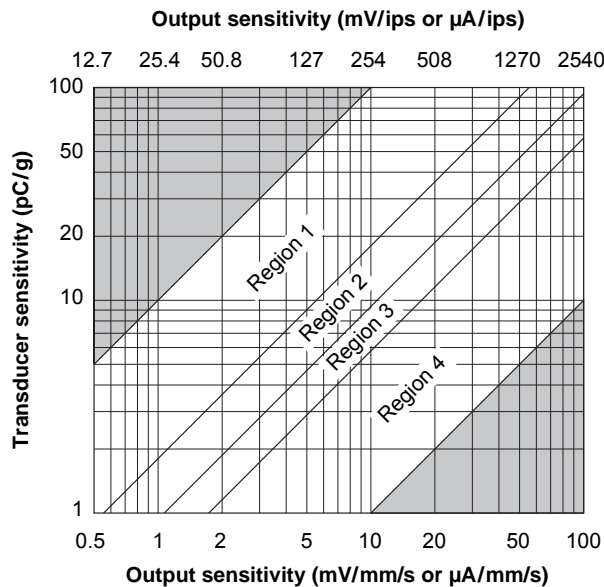

Notes

For operation in different regions of the chart, the cut-off frequency of the IPC 704's charge amplifier dictates the required high-pass filter settings. (See the HP FILTER (E) option in ordering information.)

Region 1: Cut-off frequency is 0.5 Hz → HP filter ≥ 0.5 Hz.

Region 2: Cut-off frequency is 1 Hz → HP filter ≥ 1 Hz.

Region 3: Cut-off frequency is 2 Hz → HP filter ≥ 2 Hz.

Region 4: Cut-off frequency is 3 Hz → HP filter ≥ 5 Hz.

IPC 704 for pressure sensors using standard piezoelectric materials

Ordering number 244-704-000-042-... with ordering options B07, B08, B09 and B10

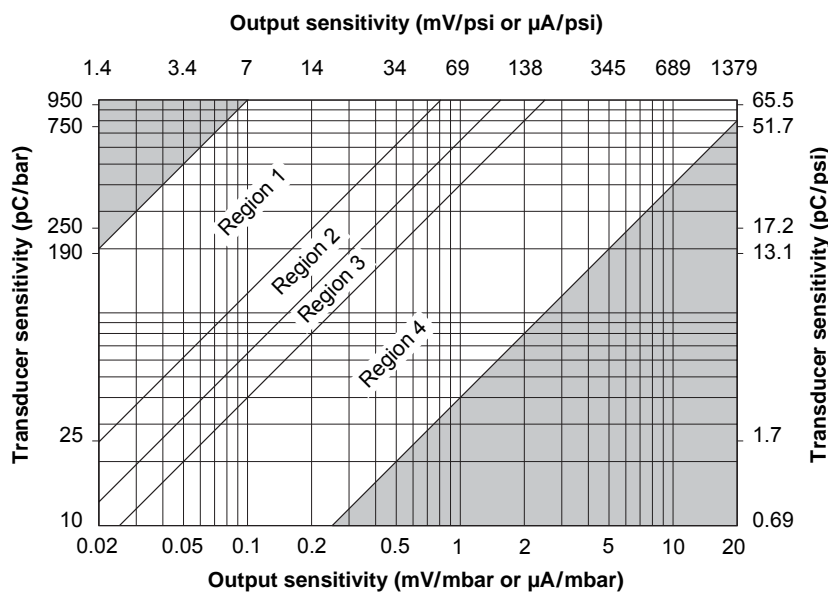

Notes

For operation in different regions of the chart, the cut-off frequency of the IPC 704's charge amplifier dictates the required high-pass filter settings. (See the HP FILTER (E) option in ordering information.)

Region 1: Cut-off frequency is 0.5 Hz → HP filter ≥ 0.5 Hz.

Region 2: Cut-off frequency is 1 Hz → HP filter ≥ 1 Hz.

Region 3: Cut-off frequency is 2 Hz → HP filter ≥ 2 Hz.

Region 4: Cut-off frequency is 3 Hz → HP filter ≥ 5 Hz.

SPECIFICATIONS (continued)

IPC 704 for pressure sensors using GaPO<sub>4</sub> piezoelectric material

Ordering number 244-704-000-511-... with ordering options B07, B08, B09 and B10

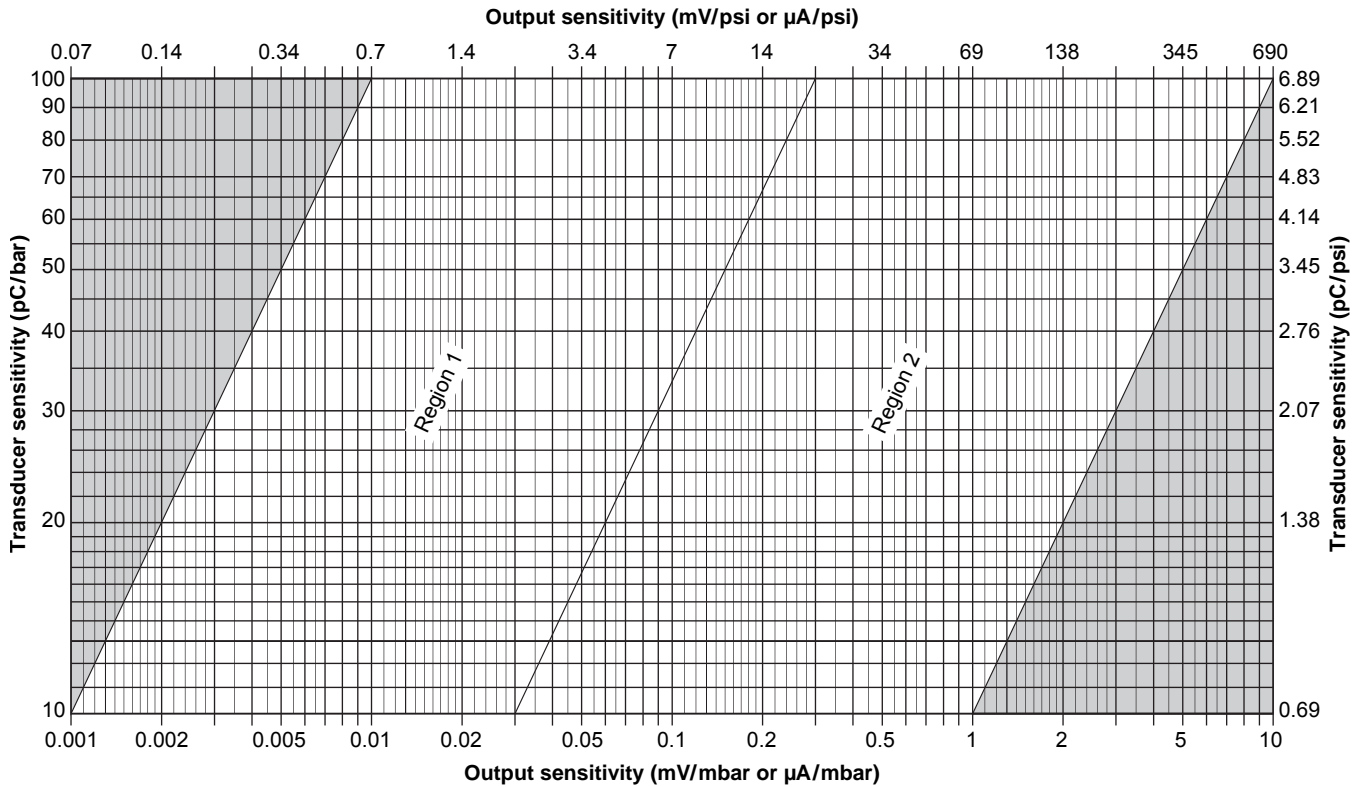

Notes

For operation in different regions of the chart, the cut-off frequency of the IPC 704's charge amplifier dictates the required high-pass filter settings. (See the HP FILTER (E) option in ordering information.)

Region 1: Cut-off frequency is 0.5 Hz → HP filter ≥ 0.5 Hz.

Region 2: Cut-off frequency is 1 Hz → HP filter ≥ 1 Hz.

Contact us

Unit 402, 4th floor, No. 42, Sharifi St., Jordan St., Tehran, Iran

Tel: 0098-2188779847-Fax 0098-2188779514

www.setc.ir-info@setc.ir

Mob:00989123840728

**SPECIFICATIONS** *(continued)*

---

**Physical characteristics**

**Signal conditioner without industrial housing (ordering option G0)**

- *Enclosure* : Injection moulded aluminium, anodized
- *Mounting* : Two or four M4 screws
- *Weight* : Standard version: 170 g  
Ex version: 250 g (the signal conditioner is moulded into silicon)
- *Dimensions* : See mechanical drawings
- *Electrical connection (input)* : Three screw terminals – wire section 2.5 mm<sup>2</sup> (max.)
- *Electrical connection (output)* : Three screw terminals – wire section 2.5 mm<sup>2</sup> (max.)

**Signal conditioner with industrial housing (ordering option G1)**

- *Enclosure* : Polyester reinforced with glass fibre
- *Cover seal* : Silicone gasket
- *Mounting* : M6 x 30 mm Allen screws
- *Dimensions* : See mechanical drawings

**Input/output stuffing glands (ordering options H and I)**

- *Type* : See ordering information
- *Material* : Nickel-plated brass with Viton® seal

**Signal conditioner with mounting adaptor (ordering option G2)**

- Universal DIN rail holder type : TSH35
- DIN rail type : EN 50022-35 x 7.5 or EN 50022-35 x 15

*Contact us*

*Unit 402, 4th floor, No. 42, Sharifi St., Jordan St., Tehran, Iran*

*Tel: 0098-2188779847-Fax 0098-2188779514*

*www.setc.ir-info@setc.ir*

*Mob:00989123840728*



MECHANICAL DRAWINGS

Signal conditioner without industrial housing (ordering option G0)

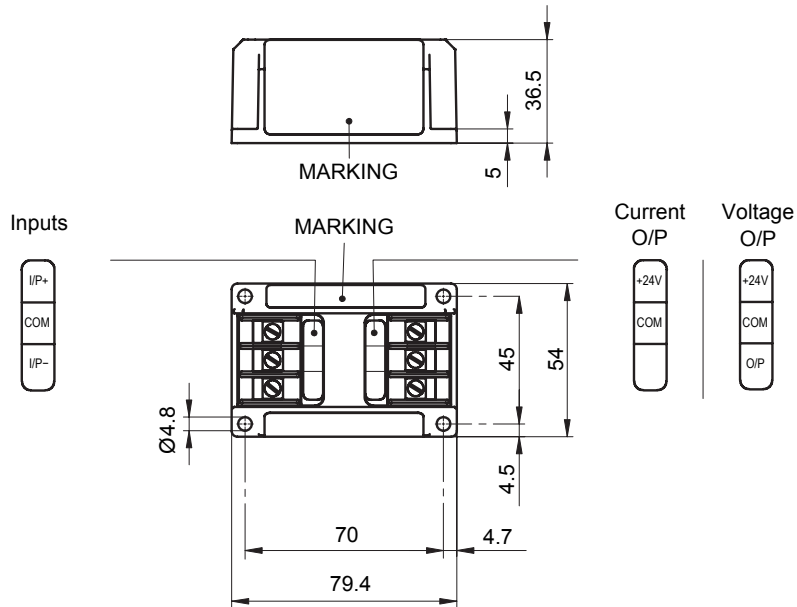

Note: All dimensions in mm unless otherwise stated.

Signal conditioner with industrial housing (ordering option G1)

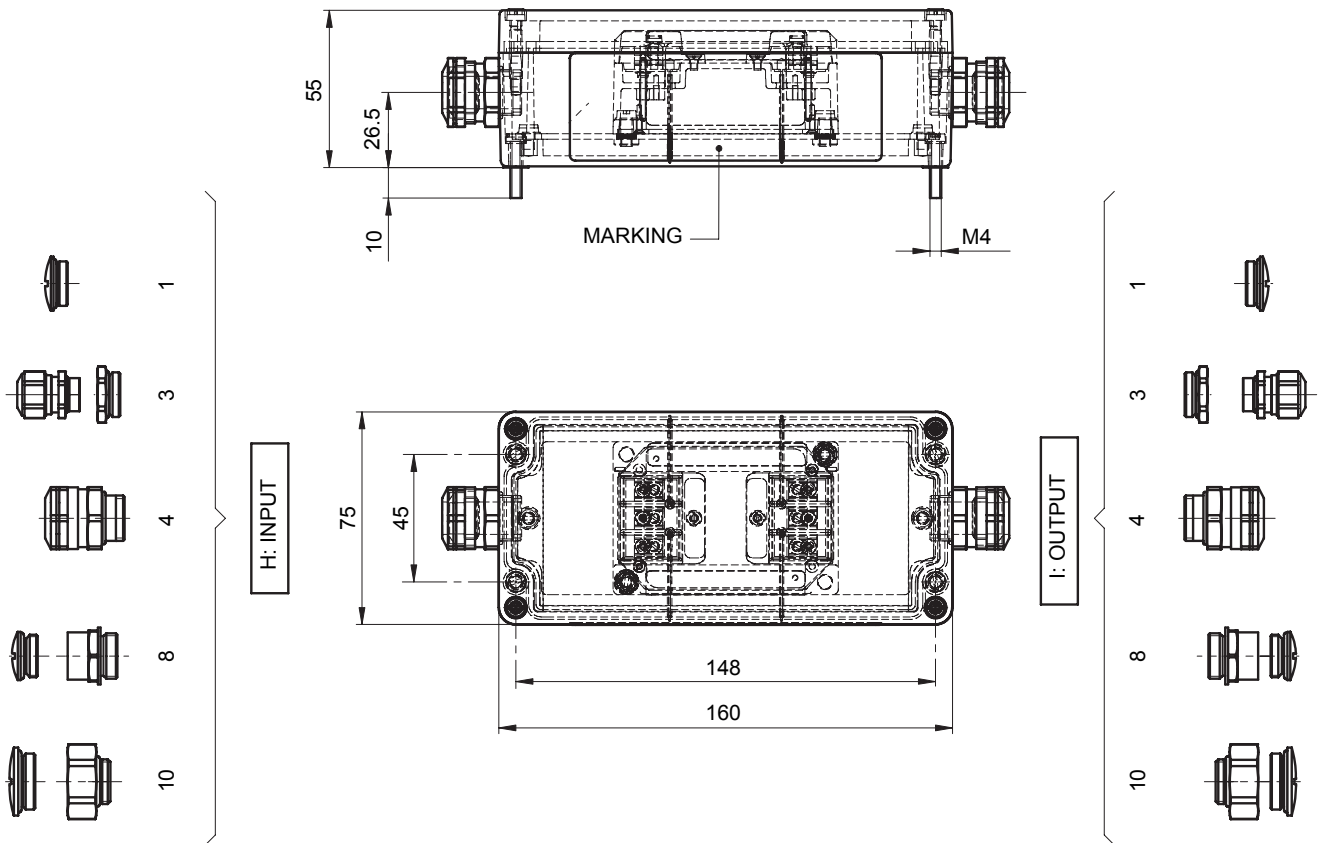

Note: All dimensions in mm unless otherwise stated.

MECHANICAL DRAWINGS (continued)

Signal conditioner with mounting adaptor (ordering option G2)

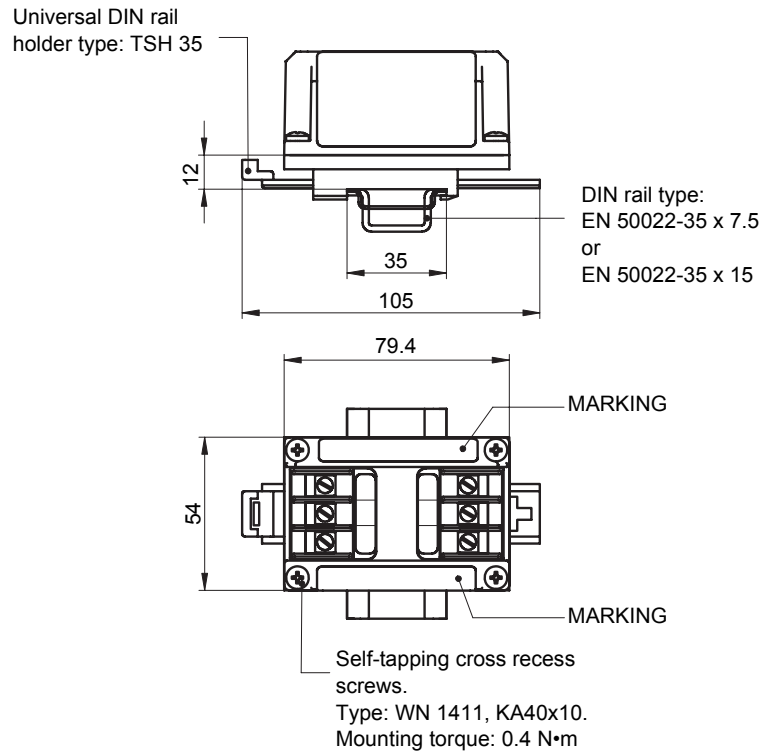

Note: All dimensions in mm unless otherwise stated.

Contact us

Unit 402, 4th floor, No. 42, Sharifi St., Jordan St., Tehran, Iran

Tel: 0098-2188779847-Fax 0098-2188779514

[www.setc.ir-info@setc.ir](mailto:www.setc.ir-info@setc.ir)

Mob:00989123840728

## ORDERING INFORMATION

### IPC 704 signal conditioner for sensors using standard piezoelectric materials

Ordering number:

244 - 704 - 000 - 042

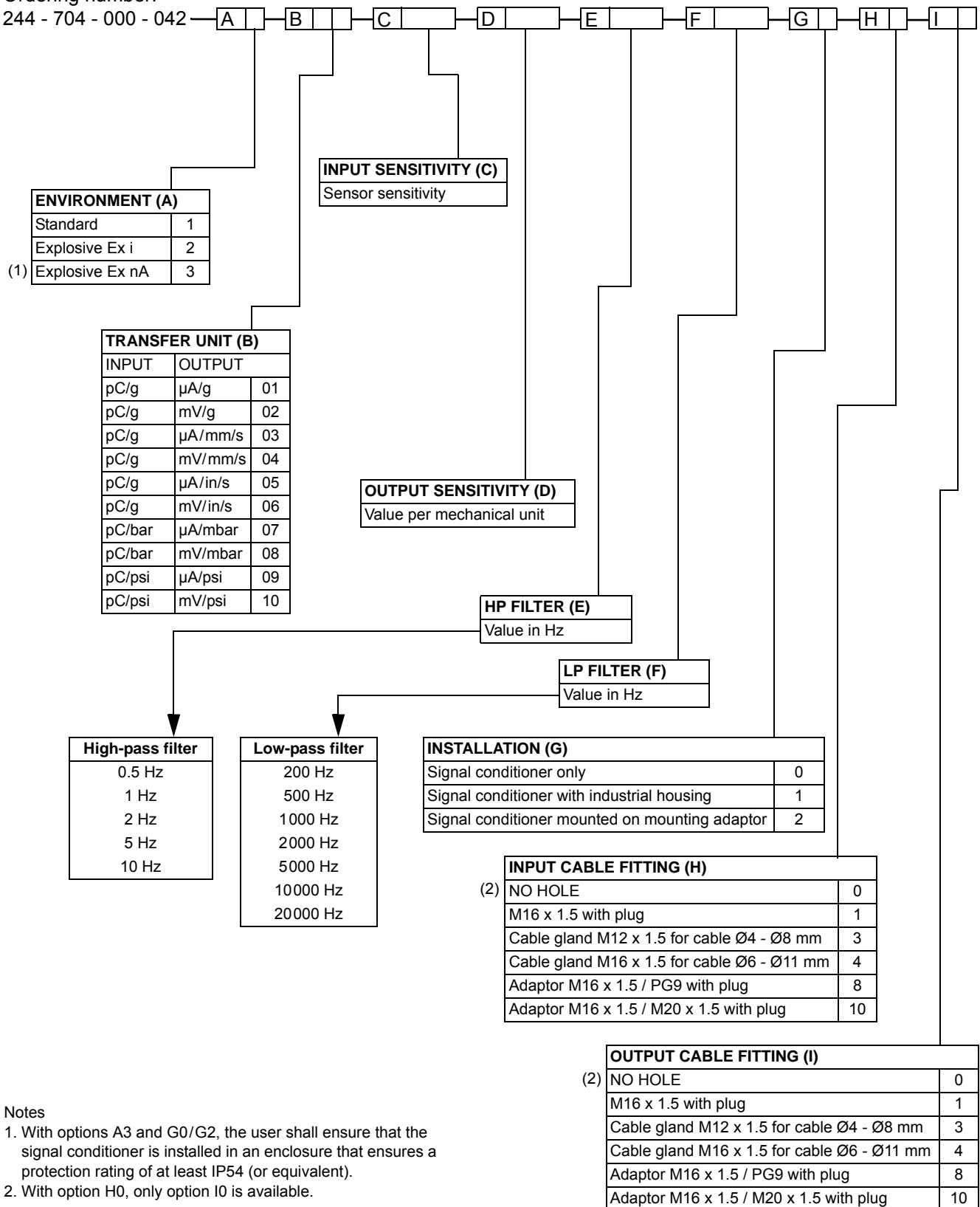

**Notes**

1. With options A3 and G0/G2, the user shall ensure that the signal conditioner is installed in an enclosure that ensures a protection rating of at least IP54 (or equivalent).
2. With option H0, only option I0 is available.

ORDERING INFORMATION (continued)

IPC 704 signal conditioner for sensors using GaPO<sub>4</sub> piezoelectric material

Ordering number:

244 - 704 - 000 - 511

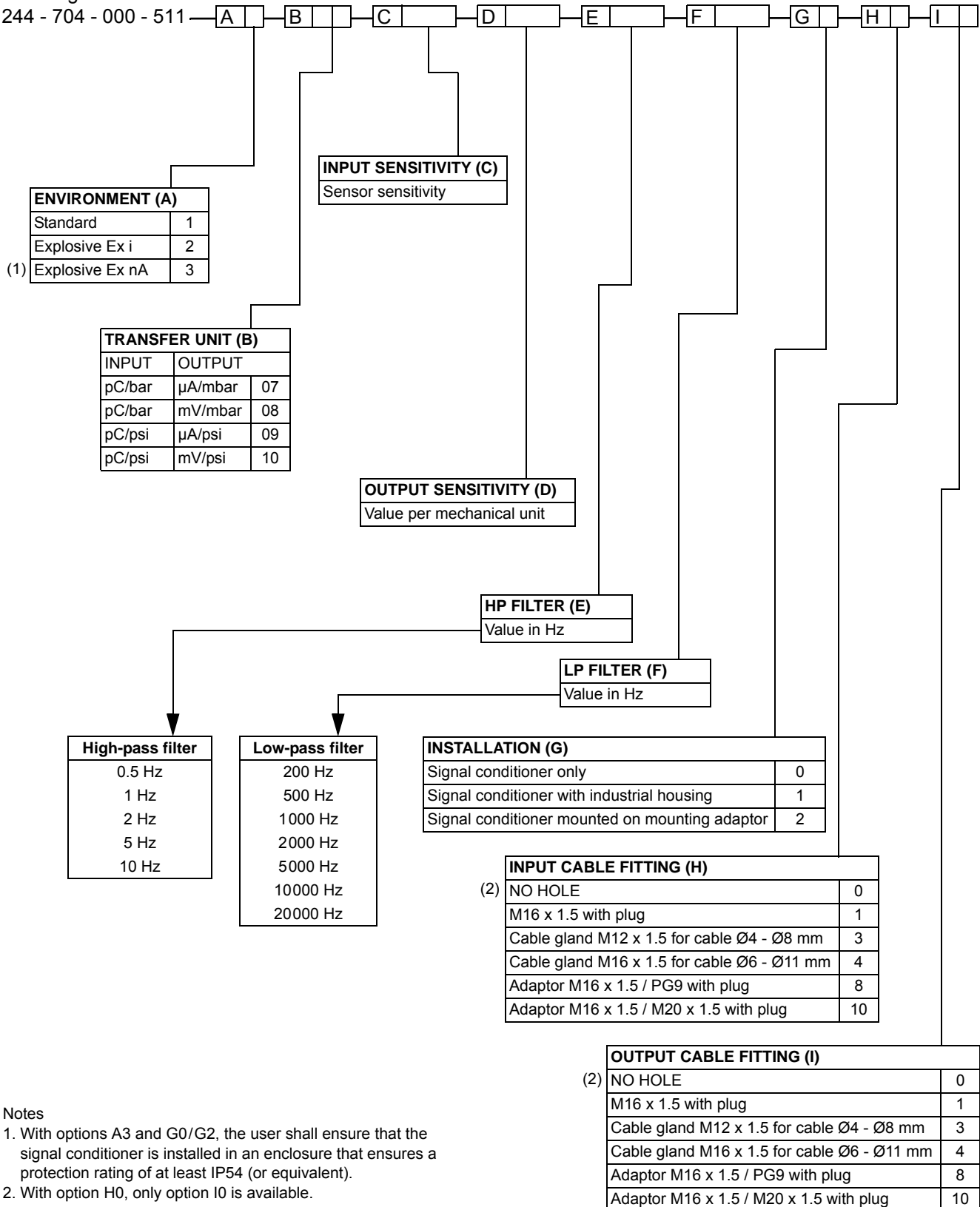

Notes

1. With options A3 and G0/G2, the user shall ensure that the signal conditioner is installed in an enclosure that ensures a protection rating of at least IP54 (or equivalent).
2. With option H0, only option I0 is available.

MOUNTING ACCESSORIES

ABA 160 industrial housing

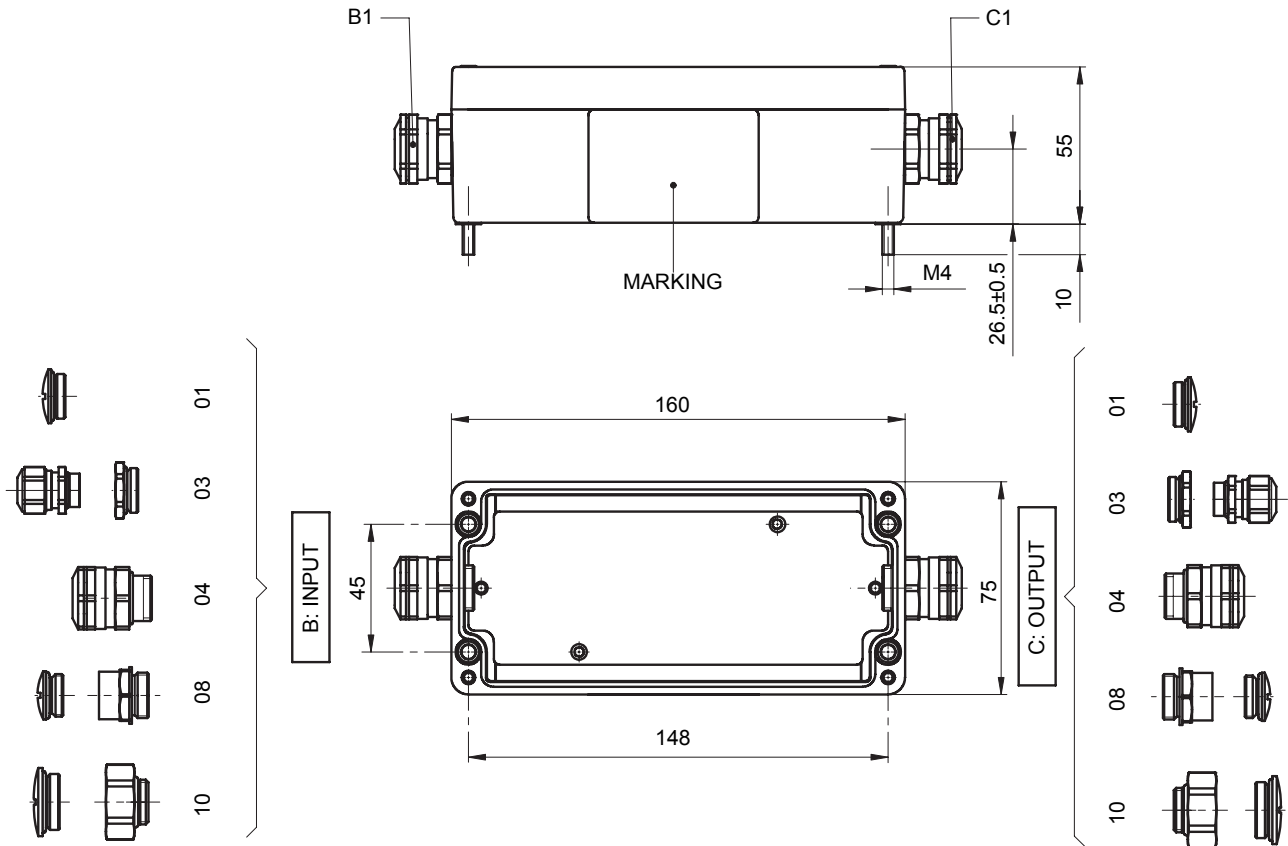

Note: All dimensions in mm unless otherwise stated.

Ordering number: 830 - 160 - 000 - 111 - A - B1 - C1

ENVIRONMENT (A)	
Standard polyester	1
(1) Explosive Ex i	2

CABLE FITTING INPUT (B)	
(2) NO HOLE	00
M16 x 1.5 with plug	01
Cable gland M12 x 1.5 for cable Ø4 - Ø8 mm	03
Cable gland M16 x 1.5 for cable Ø6 - Ø11 mm	04
Adaptor M16 x 1.5 / PG9 with plug	08
Adaptor M16 x 1.5 / M20 x 1.5 with plug (cable Ø12 mm max.)	10

CABLE FITTING OUTPUT (C)	
(2) NO HOLE	00
M16 x 1.5 with plug	01
Cable gland M12 x 1.5 for sensor cable Ø4 - Ø8 mm	03
Cable gland M16 x 1.5 for sensor cable Ø6 - Ø11 mm	04
Adaptor M16 x 1.5 / PG9 with plug	08
Adaptor M16 x 1.5 / M20 x 1.5 with plug (cable Ø12 mm max.)	10

Notes

- Suitable for potentially explosive atmospheres only when used with Ex i certified products from Meggitt Sensing Systems' Vibro-Meter product line. All machining on the industrial housing must comply with the operational manual of the housing manufacturer.
- With option B00, only option C00 is available.

MOUNTING ACCESSORIES (continued)

MA 130 mounting adaptor

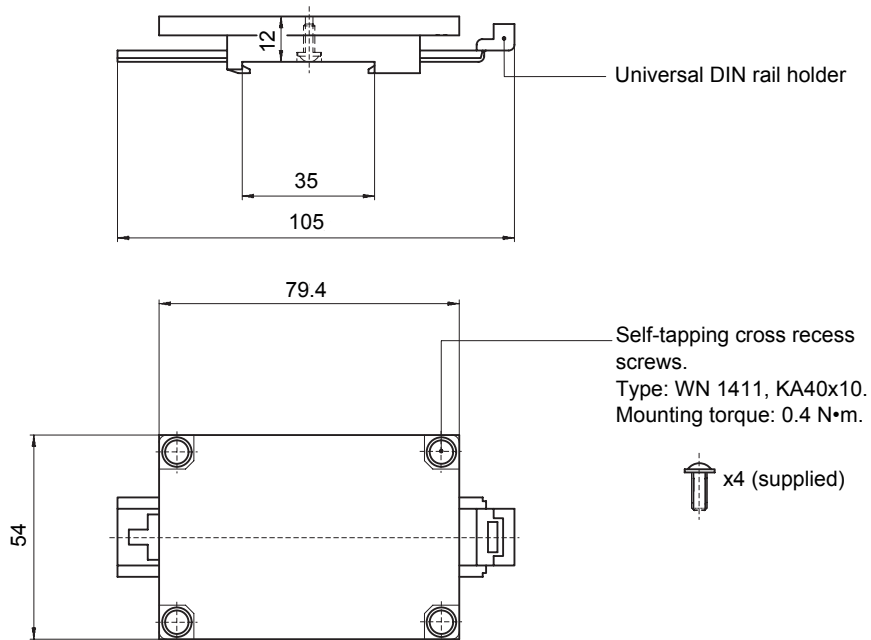

Note: All dimensions in mm unless otherwise stated.

Ordering number: 809-130-000-011

Base plate for IPC 704 signal conditioner

This aluminium base plate can be used when an old IPC 620 unit is replaced by an IPC 704 signal conditioner. The housing of the IPC 620 can be reused and the IPC 704 mounted on it.

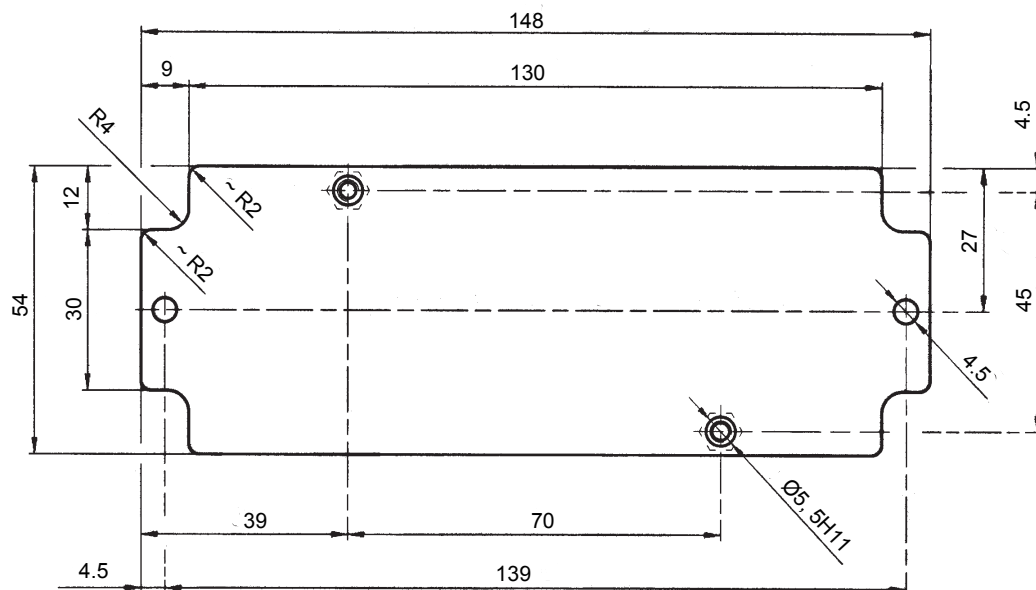

Note: All dimensions in mm unless otherwise stated.

Ordering number: 244-620-002S034

*Contact us**Unit 402, 4th floor, No. 42, Sharifi St., Jordan St., Tehran, Iran**Tel: 0098-2188779847-Fax 0098-2188779514**www.setc.ir-info@setc.ir**Mob:00989123840728*

Headquartered in the UK, Meggitt PLC is a global engineering group specializing in extreme environment components and smart sub-systems for aerospace, defence and energy markets.

Meggitt Sensing Systems is the operating division of Meggitt specializing in sensing and monitoring systems, which has operated through its antecedents since 1927 under the names of ECET, Endevco, Ferroperm Piezoceramics, Lodge Ignition, Sensorex, Vibro-Meter and Wilcoxon Research. Today, these operations are integrated under one strategic business unit called Meggitt Sensing Systems, headquartered in Switzerland and providing complete systems, using these renowned brands, from a single supply base.

The Meggitt Sensing Systems facility in Fribourg, Switzerland was formerly known as Vibro-Meter SA, but is now Meggitt SA. This site produces a wide range of vibration and dynamic pressure sensors capable of operation in extreme environments, leading-edge microwave sensors, electronics monitoring systems and innovative software for aerospace and land-based turbo-machinery.



All statements, technical information, drawings, performance rates and descriptions in this document, whilst stated in good faith, are issued for the sole purpose of giving an approximate indication of the products described in them, and are not binding on Meggitt SA unless expressly agreed in writing. Before acquiring this product, you must evaluate it and determine if it is suitable for your intended application. Unless otherwise expressly agreed in writing with Meggitt SA, you assume all risks and liability associated with its use. Any recommendations and advice given without charge, whilst given in good faith, are not binding on Meggitt SA.

Meggitt Sensing Systems takes no responsibility for any statements related to the product which are not contained in a current Meggitt Sensing Systems publication, nor for any statements contained in extracts, summaries, translations or any other documents not authored by Meggitt Sensing Systems. We reserve the right to alter any part of this publication without prior notice.

In this publication, a dot (.) is used as the decimal separator and thousands are separated by thin spaces. Example: 12345.67890.

**Sales offices**

Meggitt Sensing Systems has offices in more than 30 countries. For a complete list, please visit our website.

**Your local agent****Head office**

**Meggitt SA**  
Route de Moncor 4  
PO Box 1616  
CH - 1701 Fribourg  
Switzerland

Tel: +41 26 407 11 11  
Fax: +41 26 407 13 01

[www.meggittsensingsystems.com](http://www.meggittsensingsystems.com)  
[www.vibro-meter.com](http://www.vibro-meter.com)